

Switching Power Supply S8VS

Small Sized, DIN-Rail Mount Power Supply With LED Display

- Ultra-compact size.
- 3-digit, 7-segment LED display shows status at a glance for output voltage, output current, peak current, lifetime years, and run time hours.
- Incorporates a maintenance forecast monitor that displays the remaining life of the power supply, displayed in years.
- Run-Time monitor model displays how long the output has been on, displayed in thousands of hours.
- 90 W and above model has two outputs; one for undervoltage output and the other is for either the lifetime monitor or run time monitor.
- Approved by UL, cUL, UL508 listed, Class 2 output (60 W only).
- SEMI F47 approved.
- CE marked.
- Three year warranty.



Model Number Structure

■ Model Number Legend

S8VS-

1 2 3

1. Power Ratings

- 060: 60 W
- 090: 90 W
- 120: 120 W

2. Output voltage

24: 24 V

3. Configuration

None: Standard Power Supply

- A: With maintenance forecast monitor and undervoltage alarm (transistor (sinking))
- B: With total run time monitor and undervoltage alarm (transistor (sinking))

Ordering Information

Power ratings	Type	Output voltage	Output current	Model
60 W	Standard	24 V	2.5 A	S8VS-06024
	With maintenance forecast monitor			S8VS-06024A
	With total run time monitor			S8VS-06024B
90 W	Standard		3.75 A	S8VS-09024
	With maintenance forecast monitor			S8VS-09024A
	With total run time monitor			S8VS-09024B
120 W	Standard		5 A	S8VS-12024
	With maintenance forecast monitor			S8VS-12024A
	With total run time monitor			S8VS-12024B

Specifications

■ Ratings/Characteristics

Item	Power ratings Type	60 W			90 W			
		Standard	Maintenance forecast monitor	Total run time monitor	Standard	Maintenance forecast monitor	Total run time monitor	
Efficiency (typical)		78% min.			80% min.			
Input	Voltage	100 to 240 VAC (85 to 264 VAC)						
	Frequency	50/60 Hz (47 to 450 Hz)						
	Current	100 V input	1.7 A			2.3 A		
		200 V input	1.0 A			1.4 A		
	Power factor correction	Conforms to EN61000-3-2 A-14						
	Leakage current	100 V input	0.5 mA max.					
		200 V input	1.0 mA max.					
Inrush current (See note 1)	100 V input	25 A max.						
	200 V input	50 A max.						
Output	Voltage adjustment range	-10% to 15% (with V.ADJ)						
	Ripple	2.0% (p-p) max. (at rated input/output voltage)						
	Input variation influence	0.5% max. (at 85 to 264 VAC input, 100% load)						
	Load variation influence (rated input voltage)	1.5% max. (with rated input, 0 to 100% load)						
	Temperature variation influence	0.05%/°C max.						
	Start up time (See note 1)	1,000 ms max. (at rated input/output voltage)						
	Hold time (See note 1)	20 ms min. (at rated input/output voltage)						
Additional functions	Overload protection (See note 1)	105% to 160% of rated load current, inverted L drop, intermittent, automatic reset						
	Overvoltage protection (See note 1)	Yes						
	Output voltage indication (See note 2)	No	Yes (selectable) (See note 3)		No	Yes (selectable) (See note 3)		
	Output load indication (See note 2)	No	Yes (selectable) (See note 4)		No	Yes (selectable) (See note 4)		
	Peak-hold load indication (See note 2)	No	Yes (selectable) (See note 5)		No	Yes (selectable) (See note 5)		
	Maintenance forecast monitor indication (See note 2)	No	Yes (selectable)	No	No	Yes (selectable)	No	
	Maintenance forecast monitor output	No				Yes (open collector output), 30 VDC max., 50 mA max. (See note 6)		
	Total run time monitor indication (See note 2)	No	Yes (selectable)		No	Yes (selectable)		
	Total run time monitor output	No				Yes (open collector output), 30 VDC max., 50 mA max. (See note 6)		
	Undervoltage alarm indication (See note 2)	No	Yes (selectable)		No	Yes (selectable)		
	Undervoltage alarm output terminals	No				Yes (open collector output) 30 VDC max., 50 mA max. (See note 6)		
	Parallel operation	No						
	Series operation	Yes (with external diode)						
Other	Ambient temperature	Operating: Refer to the derating curve in <i>Engineering Data</i> . (with no icing or condensation) Storage: -25 to 65°C						
	Ambient humidity	Operating: 25% to 85%; Storage: 25% to 90%						
	Dielectric strength	3.0 kVAC for 1 min. (between all inputs and outputs/ alarm outputs; detection current: 20 mA) 2.0 kVAC for 1 min. (between all inputs and GR terminals; detection current: 20 mA) 1.0 kVAC for 1 min. (between all outputs/ alarm outputs and GR terminals; detection current: 20 mA) 500 VAC for 1 min. (between all outputs and alarm outputs; detection current: 20 mA)						
	Insulation resistance	100 MΩ min. (between all outputs/ alarm outputs and all inputs/ GR terminals) at 500 VDC						
	Vibration resistance	10 to 55 Hz, 0.375-mm single amplitude for 2 h each in X, Y, and Z directions						
	Shock resistance	150 m/s ² , 3 times each in ±X, ±Y, and ±Z directions						
	Output indicator	Yes (color: green)						
	Electromagnetic interference	Conforms to FCC Class A, EN50081-2						
	EMI	Conforms to EN50091-2:			Emission Enclosure: EN55011 class A Emission AC main: EN55011 class A			
		Conforms to EN50081-1:			Emission Enclosure: EN55011 class B Emission AC main: EN55011 class B (See note 7.)			
	Voltage sag immunity	SEMI F47-0200 (1997); no output interruption; semiconductor processing equipment voltage sag 0% of U _i for 1 second.						
	Approved standards	UL: UL508 (Listing; Class 2: Per UL1310), UL60950 cUL: CSA C22.2 No.14, No.60950 (Class 2) EN/VDE: EN50178 (=VDE0160), EN60950 (=VDE0806)			UL: UL508 (Listing), UL60950 cUL: CSA C22.2 No.14, No.60950 EN/VDE: EN50178 (=VDE0160), EN60950 (=VDE0806)			
	Weight	330 g max.			490 g max.			

- Note:**
1. Refer to the *Engineering Data* section on page 7 for details.
 2. Displayed on 7-segment LED. (character height: 8 mm)
 3. Resolution of output voltage indication: 0.1 V, Precision of output voltage indication: ±2% (percentage of output voltage value, ±1 digit)
 4. Resolution of output load indication: 0.1 A, ±5% F.S. ±1 digit max. (specified by rated output voltage)
 5. Resolution of Peak-hold load indication: 0.1 A, ±5% F.S. ±1 digit max. (specified by rated output voltage), smallest detectable signal duration: 10 ms (20 ms max.)
 6. Select from sinking or sourcing outputs.
 7. To ensure the emission enclosure rating, a ferrite ring core should be used in all cabling (TDK HF60T, HF70RH or equivalent model).

Item	Power ratings Type	120 W		
		Standard	Maintenance forecast monitor	Total run time monitor
Efficiency (typical)		80% min.		
Input	Voltage	100 to 240 VAC (85 to 264 VAC)		
	Frequency	50/60 Hz (47 to 63 Hz)		
	Current	100 V input	1.9 A	
		200 V input	1.1 A	
	Power factor correction	Conforms to EN61000-3-2 A-14		
	Leakage current	100 V input	0.5 mA max.	
		200 V input	1.0 mA max.	
Inrush current (See note 1)	100 V input	25 A max.		
	200 V input	50 A max.		
Output	Voltage adjustment range	-10% to 15% (with V.ADJ)		
	Ripple	2.0% (p-p) max. (at rated input/output voltage)		
	Input variation influence	0.5% max. (at 85 to 264 VAC input, 100% load)		
	Load variation influence (rated input voltage)	1.5% max. (with rated input, 0 to 100% load)		
	Temperature variation influence	0.05%/°C max.		
	Start up time (See note 1)	1,000 ms max. (at rated input/output voltage)		
	Hold time (See note 1)	20 ms min. (at rated input/output voltage)		
Additional functions	Overload protection (See note 1)	105% to 160% of rated load current, inverted L drop, intermittent, automatic reset		
	Overvoltage protection (See note 1)	Yes		
	Output voltage indication (See note 2)	No	Yes (selectable) (See note 3)	
	Output load indication (See note 2)	No	Yes (selectable) (See note 4)	
	Peak-hold load indication (See note 2)	No	Yes (selectable) (See note 5)	
	Maintenance forecast monitor indication (See note 2)	No	Yes (selectable)	No
	Maintenance forecast monitor output	No	Yes (open collector output), 30 VDC max., 50 mA max. (See note 6)	
	Total run time monitor indication (See note 2)	No	Yes (selectable)	
	Total run time monitor output	No	Yes (open collector output), 30 VDC max., 50 mA max. (See note 6.)	
	Undervoltage alarm indication (See note 2)	No	Yes (selectable)	
	Undervoltage alarm output terminals	No	Yes (open collector output), 30 VDC max., 50 mA max. (See note 6)	
	Parallel operation	No		
	Series operation	Yes (with external diode)		
	Other	Ambient temperature	Operating: Refer to the derating curve in <i>Engineering Data</i> . (with no icing or condensation) Storage: -25° to 65°C	
Ambient humidity		Operating: 25% to 85%; Storage: 25% to 90%		
Dielectric strength		3.0 kVAC for 1 min. (between all inputs and outputs/ alarm outputs; detection current: 20 mA)		
		2.0 kVAC for 1 min. (between all inputs and GR terminals; detection current: 20 mA)		
		1.0 kVAC for 1 min. (between all outputs/ alarm outputs and GR terminals; detection current: 20 mA)		
		500 VAC for 1 min. (between all outputs and alarm outputs; detection current: 20 mA)		
Insulation resistance		100 MΩ min. (between all outputs/ alarm outputs and all inputs/ GR terminals) at 500 VDC		
Vibration resistance		10 to 55 Hz, 0.375-mm single amplitude for 2 h each in X, Y, and Z directions		
Shock resistance		150 m/s ² , 3 times each in ±X, ±Y, and ±Z directions		
Output indicator		Yes (color: green)		
Electromagnetic interference	Conforms to FCC Class A, EN50081-2			
EMI	Conforms to EN50091-2:		Emission Enclosure: EN55011 class A Emission AC main: EN55011 class A	
	Conforms to EN50081-1:		Emission Enclosure: EN55011 class B Emission AC main: EN55011 class B (See note 7)	
Approved standards	UL: UL508 (Listing), UL60950 cUL: CSA C22.2 No.14, No.60950 EN/VDE: EN50178 (=VDE0160), EN60950 (=VDE0806)			
Weight	550 g max.			

Connections

■ Block Diagram

S8VS-06024 (60 W)

S8VS-06024□ (60 W)

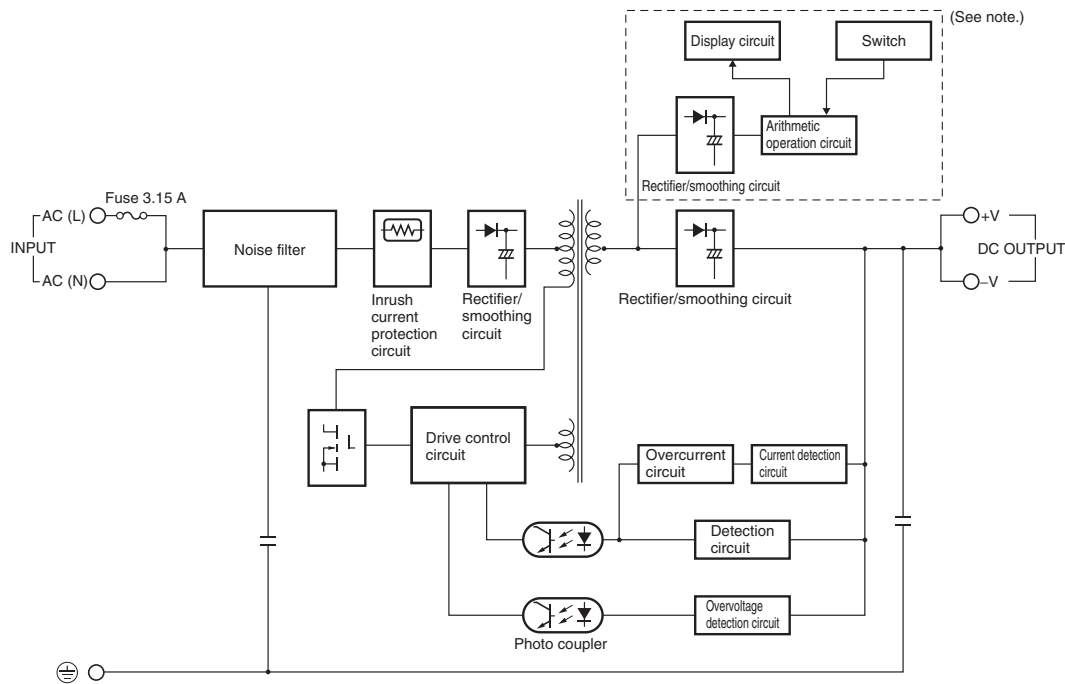

Note: The circuits within the broken line are for the S8VS-06024□ model only.

S8VS-09024 (90 W)

S8VS-09024□ (90 W)

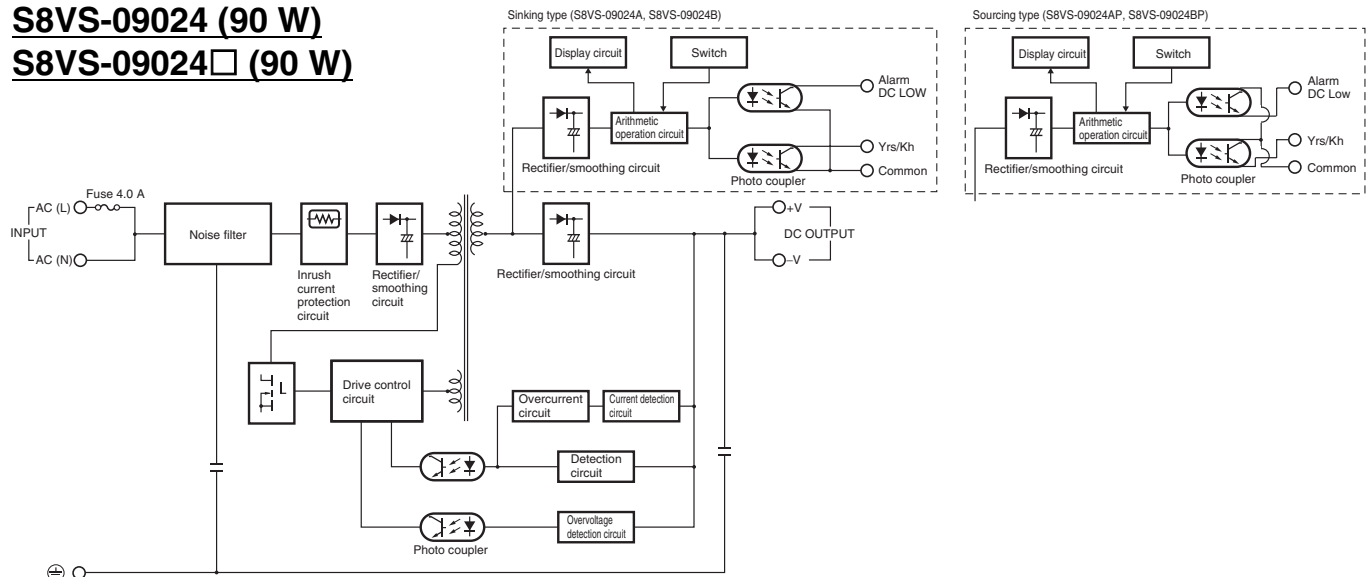

Note: The circuits within the broken line are for the S8VS-09024□ model only.

S8VS-12024 (120 W)
S8VS-12024□ (120 W)

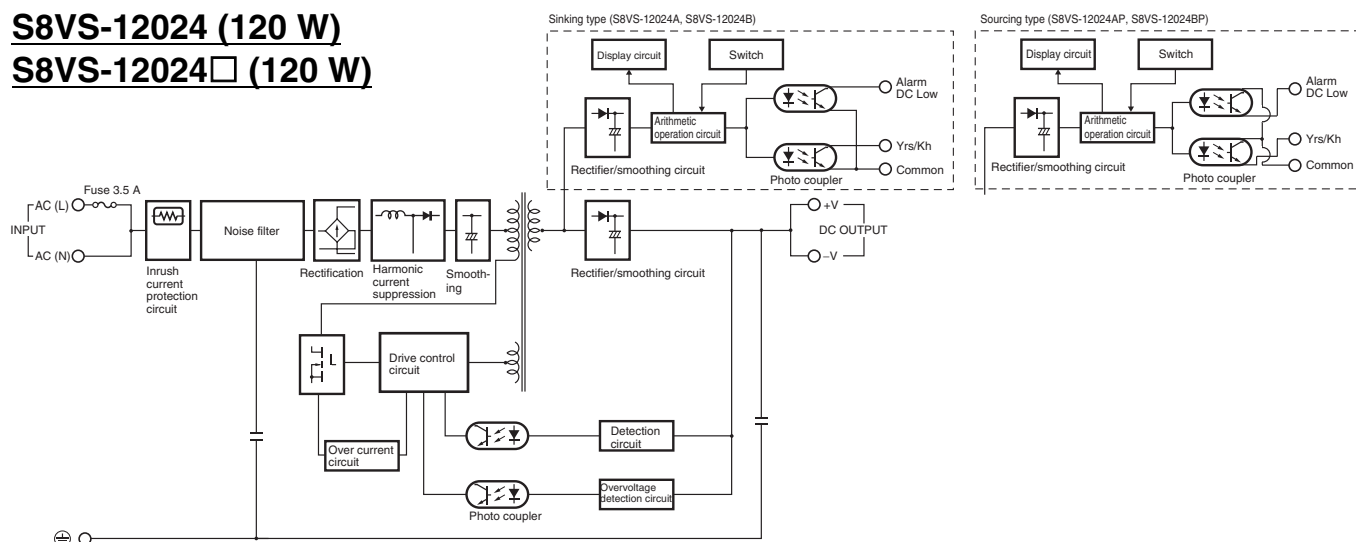

Note: The circuits within the broken line are for the S8VS-12024□ model only.

■ Installation

60-W Model

S8VS-06024

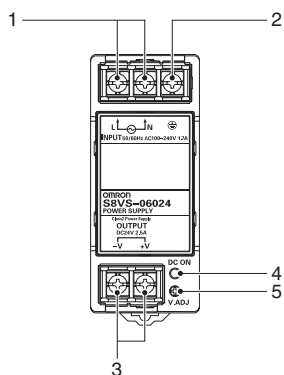

S8VS-06024□

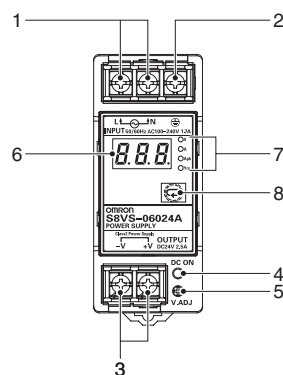

Note: The S8VS-06024A is shown above.

90-W/120-W Model

S8VS-09024
S8VS-12024

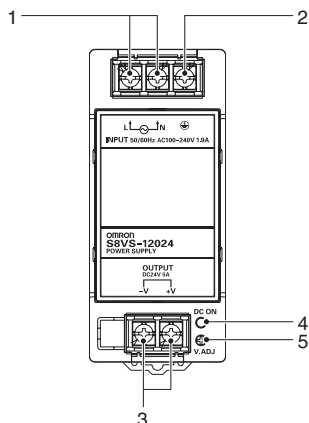

No.	Name	Function	
1	AC Input terminals (L), (N)	Connect the input lines to these terminals. (See note 1.)	
2	Ground terminals (GR)	Connect the ground line to this terminal.	
3	DC Output terminals (-V), (+V)	Connect the load lines to these terminals.	
4	Output indicator (DC ON: Green)	Lights while a direct current (DC) output is ON.	
5	Output voltage adjuster (V.ADJ)	Use to adjust the voltage.	
6	Main display (See note 2)	Indicates the measurement or set value.	
7	Operation indicator (See note 2)	V	Lights up when the output voltage is indicated. Blinks during setup of undervoltage alarm value.
		A	Lights up during indication of output current.
		Apk	Lights up during indication of peak hold current.
		Yrs	Lights up during indication of maintenance forecast monitor. Blinks during setup of maintenance forecast monitor setting. (S8VS-0□□24A)
		Kh	Lights up during indication of total run time monitor. Blinks during setup of total run time monitor. (S8VS-0□□24B)

S8VS-09024□
S8VS-12024□

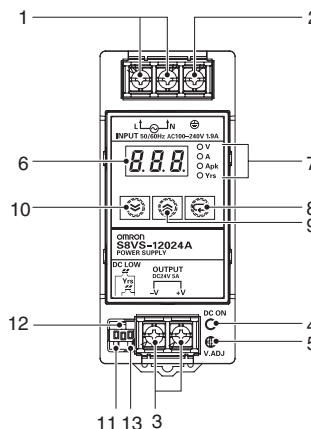

Note: The S8VS-12024A is shown above.

No.	Name	Function
8	Mode Key (See note 2.)	Use the Mode Key to change the indicated parameter or reset the peak hold current value.
9	Up Key (See note 3.)	Use the Up Key to change to the setting mode or to increase the set value.
10	Down Key (See note 3.)	Use the Down Key to change to the setting mode or to decrease the set value.
11	Alarm output terminal	Undervoltage alarm output terminal (DC LOW) (See note 3.) Outputs when a drop in the output voltage is detected. (at voltage drop: OFF)
12		Maintenance forecast monitor terminal (Yrs) S8VS-□□□24A Total run time monitor output terminal (Kh) S8VS-□□□24B (See note 3)
13	Common terminal for alarm output (See note 3)	Terminal (emitter) shared for alarm outputs (11) and (12).

- Note: 1. The fuse is located on the (L) side.
2. S8VS-□□□24□ only.
3. S8VS-□□□24□ only (excluding S8VS-06024□).

Engineering Data

Derating Curve

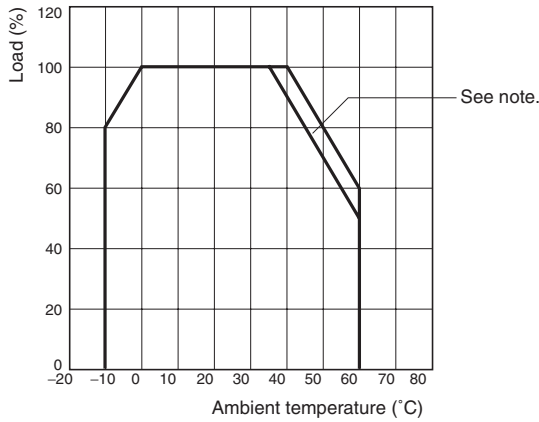

Note: Using side mounting bracket for right-side mounting (excluding 240-W models)

Installation

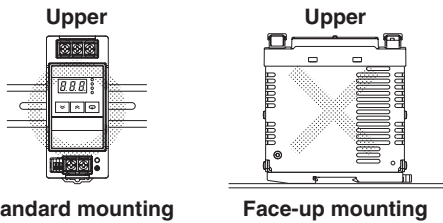

- Note:**
1. Use standard mounting only. Using any other mounting method will prevent proper heat dissipation and may result in deterioration or damage of internal elements. Or, the remaining service life notice function cannot work properly.
 2. If there is a derating problem, use forced air-cooling. The ambient temperature is specified for a point 50 mm below the power supply.

Overload Protection

The Power Supply is provided with an overload protection function that protects the load and the power supply from possible damage by overcurrent. When the output current rises above 105% min. of the rated current, the protection function is triggered, decreasing the output voltage. When the output current falls within the rated range, the overload protection function is automatically cleared.

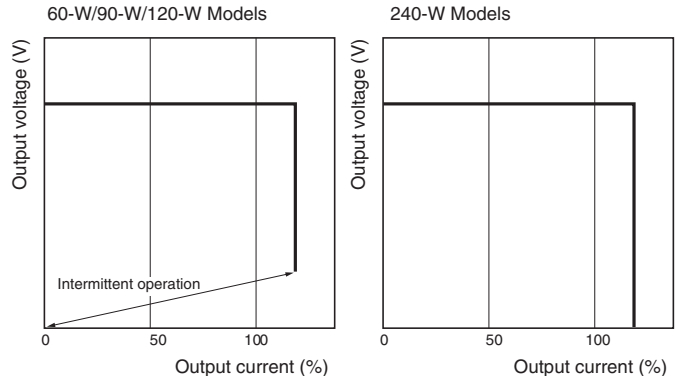

- Note:**
1. Do not allow the short-circuited or overcurrent state to continue for more than 20 s, otherwise internal elements may deteriorate or be destroyed.
 2. Do not use the Power Supply for applications with frequent inrush current or overloading at the load end, otherwise internal elements may deteriorate or be destroyed.

Overvoltage Protection

The Power Supply is provided with an overvoltage protection function that protects the load and the Power Supply from possible damage by overvoltage. When an excessive voltage is output, the output voltage is shut OFF. Reset the Power Supply by turning it OFF for at least three minutes and then turning it back ON again.

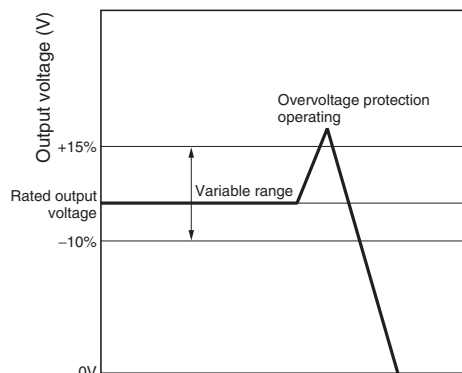

Note: Do not turn ON the power again until the cause of the overvoltage has been removed.

Undervoltage Alarm Function (Indication and Output)

When output voltage drop is detected, an alarm (*RD I*) and lowest output voltage value are indicated alternately. The preset value of detection voltage can be changed in the setting mode. (From 18.5 to 27.5 V (18.5 to 26.3 V for the S8VS-24024□), in 0.1-V steps. The value is fixed at 20 V for the S8VS-06024□.)

Further, an output ((11) DC LOW) to an external device is given from the transistor to notify of the error (excluding S8VS-06024□).



- Note:** 1. Operation begins after about two seconds since the AC power is supplied.
- 2. The alarm is not indicated in the setting mode.
- 3. Press the ((8) Mode Key) after the output voltage is restored, to reset alarm indication.
- 4. The undervoltage alarm function monitors the output terminal voltage of the power supply unit. To check the voltage accurately, measure the voltage at the load end.
- 5. The undervoltage alarm function may also operate when an interruption in AC input is not restored within 20 ms.

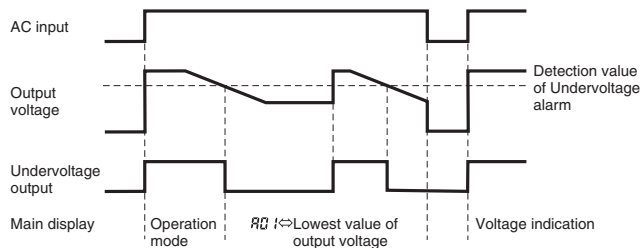

Note: Operation begins after about three seconds since the AC power is supplied.

Inrush Current, Start Up Time, Hold Time

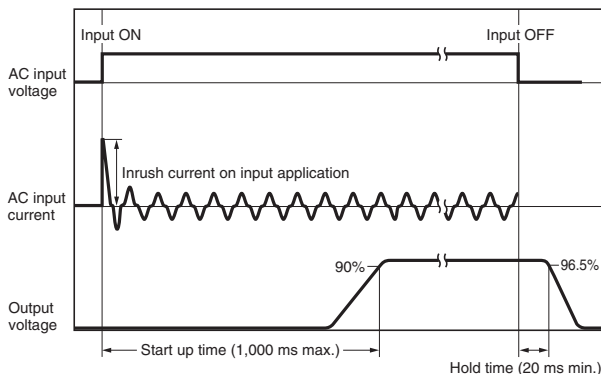

Engineering Data (S8VS-□□□24□ Only)

Mode Change

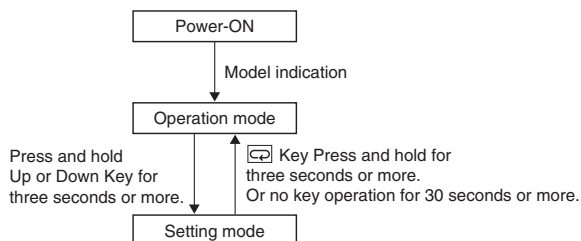

Note: No setting mode is provided for the S8VS-06024@.

Operation Mode

Various states of the power supply unit are indicated.

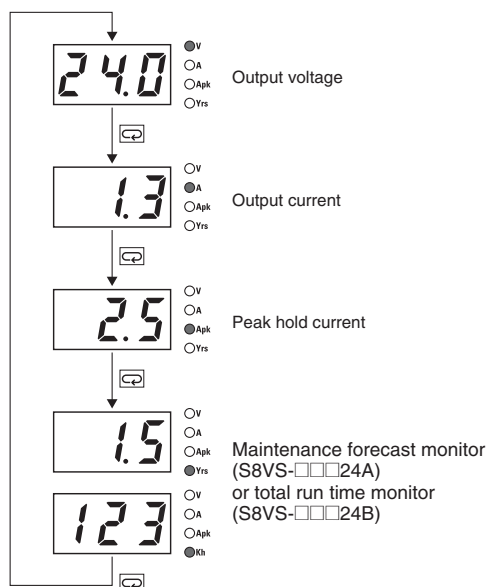

Note: The output voltage will be displayed when the power supply is first turned on after it is received from the factory. Thereafter, the output voltage will be indicated in the same display when shutting down.

Setting Mode (Except for S8VS-06024□)

Set various parameters of the power supply unit.

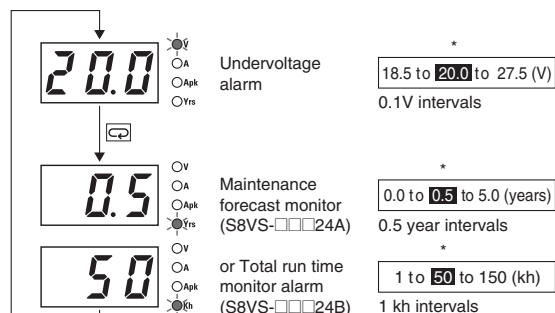

* The reverse video indicates the shipment setting.

- Note: 1.** Press and hold the (9) Up Key or (10) Down Key for two seconds or more to increase or decrease the value rapidly.
- 2.** The S8VS-06024□ is not provided with the setting mode and its parameters are fixed at the shipment setting.

Peak Hold Current Reset

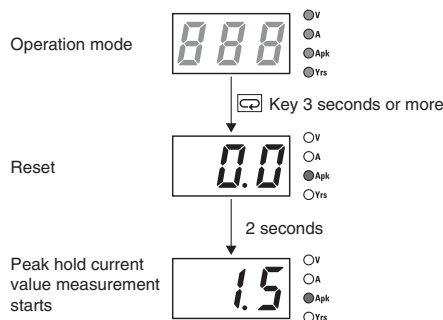

Note: The peak hold current value is not reset in the setting mode.

Total Run Time Monitor Indication and Alarm Output (S8VS-□□□24B)

The cumulative running hours of the power supply unit are monitored as total run time. When the total run time reaches the predetermined alarm set value, an alarm (A02) and the total run time monitor are indicated alternately with an output issued from the transistor ((12) Kh) to an external device. (The output is turned off when the total run time reaches the alarm set value; with no continuity across (12) and (13).)

The alarm set value can be changed in the setting mode.



- Note: 1.** The total run time cannot be reset. To reset the alarm, increase the alarm set value beyond the value indicated as total run time. Ex.) If a customer decided to change the load at 5,000 hours, when they turn the unit again the timing will start at 5,000 hours and on.
- 2.** The alarm function (setting, indication, and output) is not provided for S8VS-06024B.

Self-Diagnostics Function

(6) Main display	Description	Output state	Restoration method	Setting after restoration
- - -	Noise detected in voltage or current	No change	Automatic restoration	No change
Hot	Overheated	(12) OFF	Automatic restoration	No change
E01	Undervoltage alarm set value memory error	(11) OFF	Press and hold the (9) Up Key or (10) Down Key for three seconds and check the set value of the corresponding point. The set value must return to the shipment setting	Shipment setting or value set in the setting mode again
E02	Memory error of alarm set value of maintenance forecast monitor or total run time monitor	(12) OFF	Press and hold the (9) Up Key or (10) Down Key for three seconds and check the set value of the corresponding point. The set value must return to the shipment setting	Shipment setting or value set in the setting mode again
E03	Other memory error	(11) (12) OFF	Turn the AC input off then on again. If the product is not reset, contact the dealer.	No change

- Note:**
- External noise is probable as a cause of “- - -”, “E01”, “E02” and “E03” errors.
 - Operation out of the derating curve area, ventilation error, and incorrect mounting direction are probable as a cause of “Hot” error.
 - If the “Hot” error state continues for about three hours, the maintenance forecast monitor function (S8VS-@@@24A) becomes invalid. The indication for maintenance forecast monitor remains as “Hot” even after the overheat condition is removed, and the Yrs output (12) remains OFF (with no continuity across (12) and (13)).
Replace the power supply if this condition occurs even if the output is correct, as internal parts may be deteriorated.
 - The “Hot” error detection function is only for the S8VS-□□□24A.

Undervoltage Alarm Indication

This indicator lights when the output voltage is insufficient.

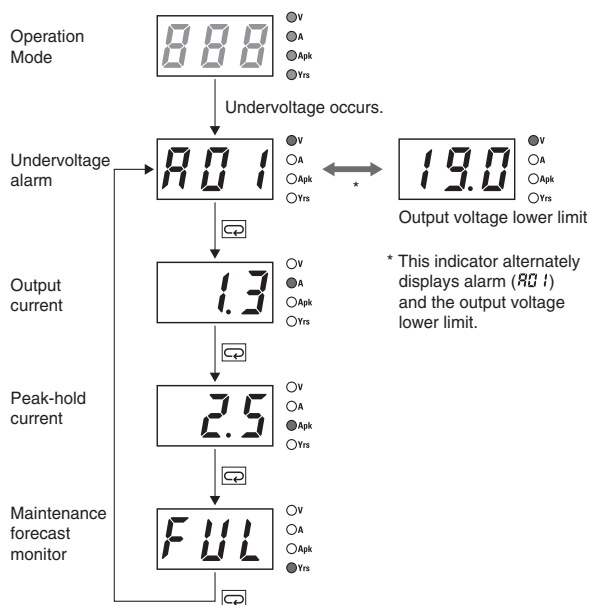

Note: The display changes to the output voltage display when the voltage is restored to the set value or higher.

Multiple Alarms

When two or more different alarms occur at the same time

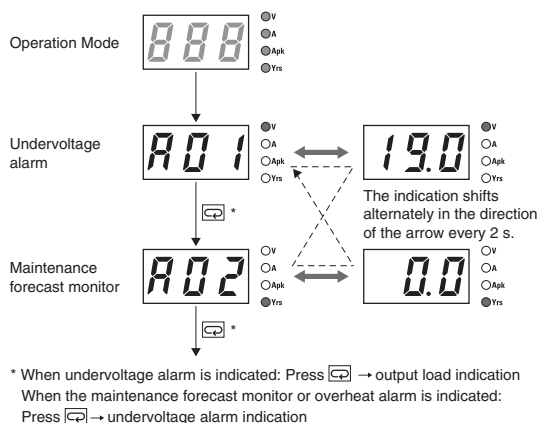

Maintenance Forecast

Displays when the maintenance forecast has reached the set value.

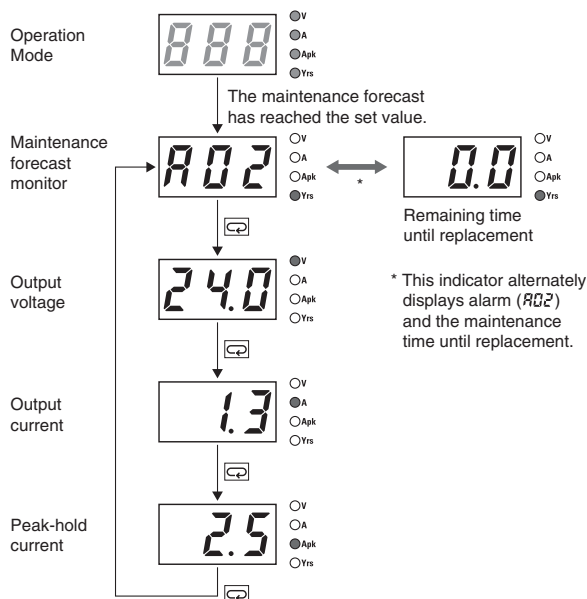

Indication and Output

When the product is purchased, "FUL" will be indicated. As electrolytic capacitors deteriorate, indication changes to "HLF". (However, the "HLF" indication may not appear, depending on the usage environment and the set value for maintenance forecast.)

S8VS-06024A:

After the remaining time to maintenance is reduced to two years, indication automatically changes to a value, which decreases from "1.5" to "1.0" to "0.5" to "0.0" (year) as the running hours increase. If the remaining time becomes less than 0.5 year, an alarm (A02) and "0.0" are indicated alternately.

S8VS-09024A, S8VS-12024A, S8VS-24024A:

If the maintenance forecast setting L (which can be set arbitrarily from 0.0 to 5.0 years in 0.5-year steps) is set to a value larger than two years, the indication automatically changes to a value (L - 0.5) after the remaining time to maintenance is reduced to the set years, and an alarm (A02) and the remaining time are indicated alternately.

If the setting is less than 2.0 years, the indication changes to a value (1.5) after the remaining time becomes less than two years, and after the remaining time becomes less than the set time, an alarm (A02) and the remaining time (L - 0.5) are indicated alternately.

While the alarm (A02) and value are indicated alternately, an output is given to an external device from a transistor ((12) Yrs) to notify of the replacement timing. (The output is turned OFF after the replacement timing is reached; with no continuity across (12) and the alarm common output terminal.)



- Note: 1.** The remaining time to maintenance is based on continuous operation, not including the time when the power supply is turned off, and so may take longer to reach than the actual time indicated.
- 2.** Until the power supply has been turned for about one month in total, indication is fixed at "FUL" to estimate the extent of deterioration, while the output remains turned on (with continuity across (12) and (13)).

Maintenance Forecast Monitor Function

The power supply unit is equipped with electrolytic capacitors.

The electrolyte inside the electrolytic capacitor penetrates the sealing rubber and evaporates as time passes since it is manufactured, which causes deterioration of characteristics such as decreasing the capacitance, etc.

Due to this deterioration of the characteristics of the electrolytic capacitor, the power supply unit decreases its performance as time passes.

The maintenance forecast monitor function shows an approximate period left for maintenance of the power supply unit due to deterioration of electrolytic capacitors. When the period left for maintenance that the power supply forecasts reaches the set value, an alarm is indicated and an output signal is triggered.

Use this function to know the approximate replacement timing of the power supply unit.

Note: The maintenance forecast monitor function indicates an approximate period left for maintenance, based on deterioration of the electrolytic capacitor. It does not predict failures caused by other reasons.

Relationship Between Indicated Values and Output of Set Values

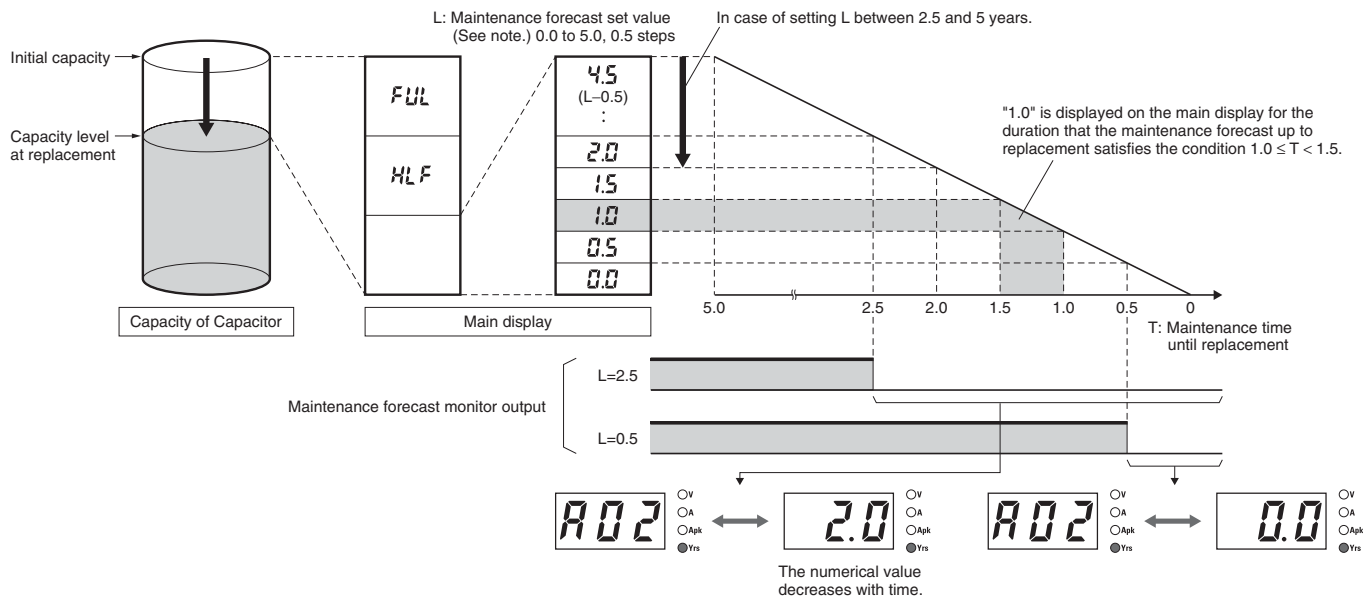

Note: This function can be set only on the S8VS-□□□24A models (except the S8VS-06024A).

Principle of Operation

The deterioration speed of the electrolytic capacitor varies considerably according to the ambient temperature. (Generally the speed follows "Rule of Two for every 10°C"; for every 10°C increase in temperature the rate of degradation doubles according to Arrhenius's equation.) The S8VS-□□□24A monitors the temperature inside the power supply, and calculates the amount of deterioration according to the running hours and inside temperature. Judging by this amount of deterioration, the power supply will give the alarm indication and output when the period left for maintenance reaches the set value.

- Note:**
1. Due to degradation of internal electronic parts, replace the power supply at least once every 15 years even if indication and output of maintenance forecast monitor are not issued.
 2. The maintenance forecast is accelerated or decelerated according to operating conditions. Periodically check indication.
 3. Acceleration or deceleration of the maintenance forecast may cause the output to repeatedly go ON/OFF. Only the S8VS-09024A, S8VS-12024A, and S8VS-24024A are equipped with output.
 4. The accuracy of the maintenance forecast function may be adversely affected by applications in which the AC input is frequently turned ON/OFF.

Reference Value

Item	Value	Definition
Reliability (MTBF)	135,000 hrs min.	MTBF stands for Mean Time Between Failures, which is calculated according to the probability of accidental device failures, and indicates reliability of devices. Therefore, it does not necessarily represent a life of the product.
Life expectancy	10 yrs. min.	The life expectancy indicates average operating hours under the ambient temperature of 40°C and a load rate of 50%. Normally this is determined by the life expectancy of the built-in aluminum electrolytic capacitor.

Note: The maintenance forecast is the service life (the power supply's internal temperature is monitored at all times) of the internal electrolytic capacitor in actual operating conditions, and varies according to the customer's operating conditions. 15 years is taken as the maximum period of the maintenance forecast.

Dimensions

Unit: mm

S8VS-06024 (60 W)
S8VS-06024□ (60 W)

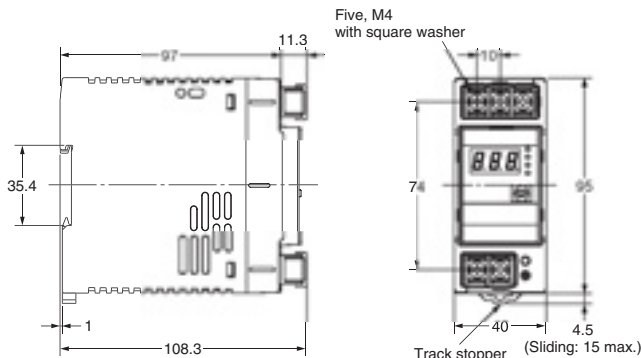
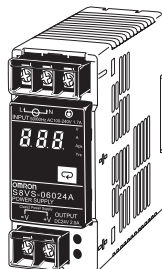

Note: The illustration is the S8VS-06024A Model.

S8VS-09024 (90 W)/S8VS-12024 (120 W)
S8VS-09024□ (90 W)/S8VS-12024□ (120 W)

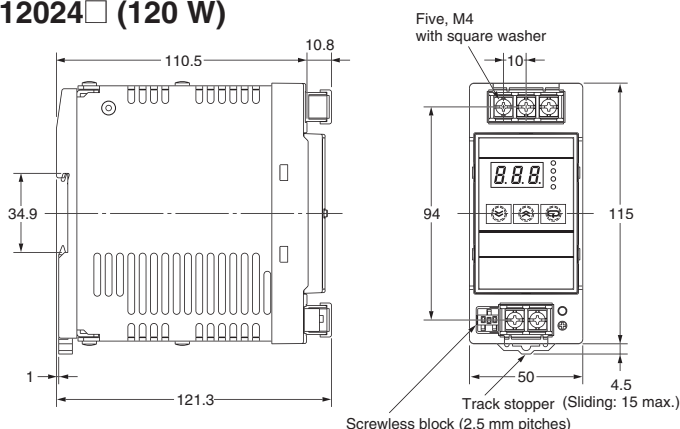
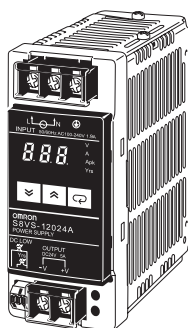

Note: The illustration is the S8VS-12024A Model.

■ DIN Track (Order Separately)

Mounting Track (Material: Aluminum)

PFP-100N
PFP-50N

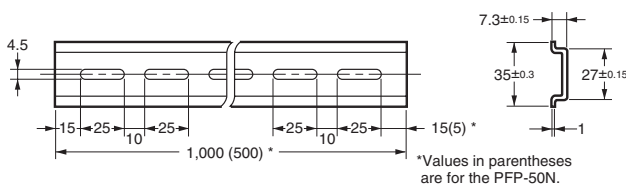
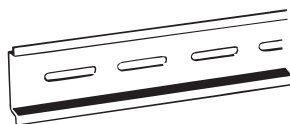

Mounting Track (Material: Aluminum)

PFP-100N2

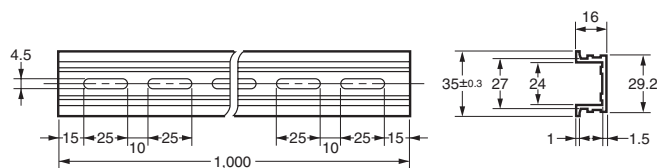
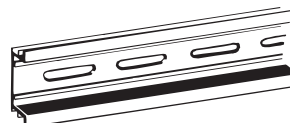

Unit: mm

End Plate

PFP-M

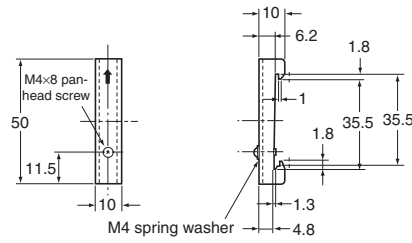
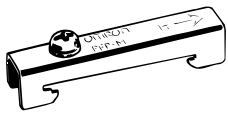

■ Mounting Brackets

Type	Side-mounting Bracket (For 60-, 90-, 120-W types)	Side-mounting Bracket (For 240-W type)	Front-mounting Bracket
Model	S82Y-VS10S	S82Y-VS20S	S82Y-VS10F
Dimensions			
Appearance	Left-side mounting Right-side mounting	Left-side mounting *Right-side mounting also possible.	(For 60-, 90-, 120-W types) (For 240-W type) *Use two S82Y-VS10F brackets for the 240-W type.

Warranties, Limitations of Liability

■ WARRANTY

OMRON's exclusive warranty is that the products are free from defects in materials and workmanship for a period of three years (or other period if specified) from date of sale by OMRON.

OMRON MAKES NO WARRANTY OR REPRESENTATION, EXPRESSED OR IMPLIED, REGARDING NON-INFRINGEMENT, MERCHANTABILITY OR FITNESS FOR PARTICULAR PURPOSE OF THE PRODUCTS. ANY BUYER OR USER ACKNOWLEDGES THAT THE BUYER OR USER ALONE HAS DETERMINED THAT THE PRODUCTS WILL SUITABLY MEET THE REQUIREMENTS OF THEIR INTENDED USE. OMRON DISCLAIMS ALL OTHER WARRANTIES, EXPRESSED OR IMPLIED.

■ LIMITATIONS OF LIABILITY

OMRON SHALL NOT BE RESPONSIBLE FOR SPECIAL, INDIRECT OR CONSEQUENTIAL DAMAGES, LOSS OF PROFITS OR COMMERCIAL LOSS IN ANY WAY CONNECTED WITH THE PRODUCTS, WHETHER SUCH CLAIM IS BASED ON CONTRACT, WARRANTY, NEGLIGENCE OR STRICT LIABILITY.

In no event shall responsibility of OMRON for any act exceed the individual price of the product on which liability is asserted.

IN NO EVENT SHALL OMRON BE RESPONSIBLE FOR WARRANTY, REPAIR OR OTHER CLAIMS REGARDING THE PRODUCTS UNLESS OMRON'S ANALYSIS CONFIRMS THAT THE PRODUCTS WERE PROPERLY HANDLED, STORED, INSTALLED AND MAINTAINED AND NOT SUBJECT TO CONTAMINATION, ABUSE, MISUSE, OR INAPPROPRIATE MODIFICATION OR REPAIR.

Application Considerations

■ SUITABILITY FOR USE

OMRON shall not be responsible for conformity with any standards, codes or regulations which apply to the combination of products in the customer's application or use of the products.

Take all necessary steps to determine the suitability of the product for the systems, machines and equipment with which it will be used.

Know and observe all prohibitions of use applicable to this product.

NEVER USE THE PRODUCT FOR AN APPLICATION INVOLVING SERIOUS RISK TO LIFE OR PROPERTY WITHOUT ENSURING THAT THE SYSTEM AS A WHOLE HAS BEEN DESIGNED TO ADDRESS THE RISKS, AND THAT THE OMRON PRODUCT IS PROPERLY RATED AND INSTALLED FOR THE INTENDED USE WITHIN THE OVERALL EQUIPMENT OR SYSTEM.

Precautions

! Caution

Do not disassemble the product or touch internal parts. Electric shock may be caused.

Do not touch the product during power-on, and immediately after power-off. Hot surface may cause heat injury.

Tighten the terminal screw with torque 1.08 N·m. A loose screw may cause fire.

Install the terminal cover. Electric shock may be caused if not installed.

Mounting

Be sure to allow convection in the atmosphere around devices when mounting. Do not use in locations where the ambient temperature exceeds the range of the derating curve.

When cutting out holes for mounting, make sure that cuttings do not enter the interior of the products.

Before turning the Power Supply ON, be sure to remove sheets that were used as covers during mounting, and make sure that heat release is not obstructed.

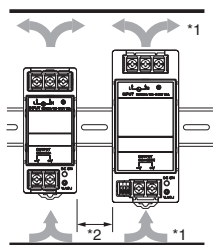

*1. Convection of air
*2. 20 mm min.

Wiring

Ground the product (GR) completely. Failure to do so could cause electric shock or malfunction.

Ensure that input and output terminals are wired correctly.

Do not apply more than 100N force to the terminal block when tightening it.

Be sure to remove the sheet covering the product for machining before power-on.

Recommended Wire Type

Model	Recommended wire size	
	For screw terminal	For alarm output terminal
S8VS-06024□	AWG14 to 20 (Cross section 0.517 to 2.081mm ²)	---
S8VS-09024□ S8VS-12024□ S8VS-24024□	AWG14 to 18 (Cross section 0.823 to 2.081mm ²)	AWG18 to 28 (Cross section 0.081 to 0.823mm ²) (Use only AWG18 stranded wire for UL508 Listing.)

Installation Environment

Do not use the Power Supply in locations subject to shocks or vibrations. In particular, install the Power Supply as far away as possible from contactors or other devices that are a vibration source.

Install the Power Supply well away from any sources of strong, high-frequency noise.

Operating and Storage Environments

Do not use or store the Power Supply in the following locations. Doing so may result in failure, malfunction, or deterioration of performance characteristics.

- Do not use in locations subject to direct sunlight.
- Do not use in locations where the ambient temperature exceeds the range of the derating curve.
- Do not use in locations where the humidity is outside the range 25% to 85%, or locations subject to condensation due to sudden temperature changes.
- Do not store in locations where the ambient temperature is outside the range -25 to 65°C or where the humidity is outside the range 25% to 90%.
- Do not use locations where liquids, foreign matter, corrosive gases, or flammable gases may enter the interior of products.

S8VS-□□□24A Model Only

Satisfy the following conditions when storing the Power Supply for long periods of time to maintain its remaining service life function.

- When storing for more than three months, store within an ambient temperature range of -25 to +30°C and the humidity range of 25 to 70%.

Periodic Check (S8VS-□□□24A/- □□□24B Except for S8VS-06024A/- 06024B)

It may take from several years to several tens of years under general operating conditions for the power supply to output the maintenance forecast monitor alarm (S8VS-□□□24A). The total run time monitor (S8VS-□□□24B) may be a similar number of years as the maintenance forecast monitor according to some settings. During operation over an extended period of time, periodically check if the maintenance forecast monitor output ((12)Yrs) or total run time monitor output ((12)kh) is correctly functioning by the following procedure.

1. Select the operation mode.
2. Check that the output ((12)Yrs/kh) is turned ON (with continuity across (12) and (13)).
3. In the operation mode, press and hold the Down Key (10) and the Mode Key (8) simultaneously for at least three seconds. The main display (6) changes to "RD2." An inactive output ((12)Yrs/kh) (no continuity across (12) and (13)) in the "RD2" indication indicates the correct function.
4. Release keys to return to the regular state.

Note: DC output stays ON during the periodical check.

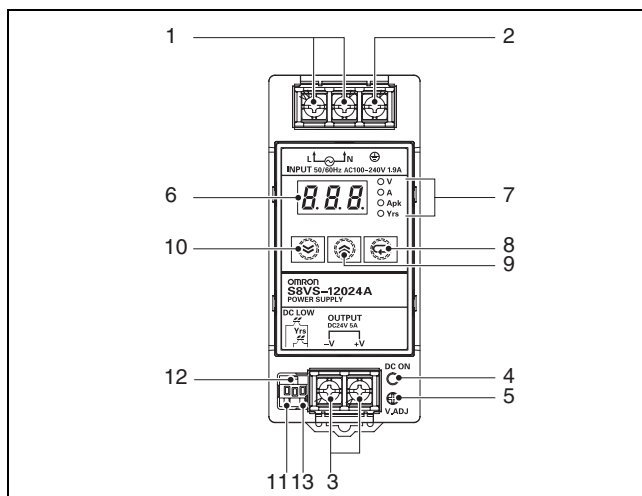

Charging the Battery

If a battery is to be connected as the load, mount an overcurrent limiting circuit and an overvoltage protection circuit.

Output Voltage Adjuster

Do not add unnecessary power. The output voltage adjuster (V.ADJ) may be damaged.

If the output voltage is set to a value less than 20 V, the undervoltage alarm function may operate.

DIN Track Mounting

To mount the Block on a DI track, hook portion (A) of the Block onto the track and press the Block in direction (B).

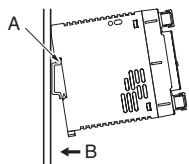

To dismount the Block, pull down portion (C) with a flat-blade screwdriver and pull out the Block.

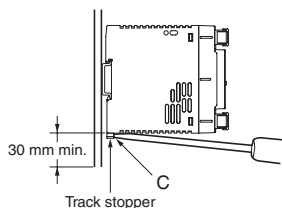

Series Operation

Two power supplies can be connected in series.

The (±) voltage output can be accomplished with two power supplies.

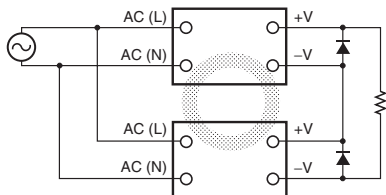

Note: 1. Connect the diode as shown in the figure. If the load is short-circuited, a reverse voltage may be applied inside the power supply unit, causing deterioration or breakage of the power supply unit.

Select a diode having the following ratings.

Type	Schottky Barrier diode
Dielectric strength (VRRM)	Twice the rated output voltage or above
Forward current (IF)	Twice the rated output current or above

2. Though products having different specifications can be connected in series, the current flowing through the load must not exceed the smaller rated output current.

Parallel Operation

The product is not designed for parallel operation.

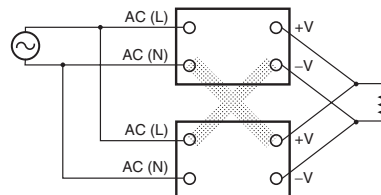

In Case There is No Output Voltage

The possible cause for no output voltage may be the presence of an overload or overvoltage condition, or may be due to the functioning of a latching protective device. The latching protection may operate if a large amount of surge voltage such as a lightning surge occurs while turning on the power supply.

In case there is no output voltage, please check the following points before contacting us:

Check the Overload Protected Status:

- Check whether the load is in overload status or is short-circuited. Remove wires to load when checking.
- Attempt to clear the overvoltage or latching protection function: Turn the power supply off once, and leave it off for at least 3 minutes. Then turn it on again to see if this clears the condition.

ALL DIMENSIONS SHOWN ARE IN MILLIMETERS. To convert millimeters into inches, divide by 25.4

OMRON

OMRON ELECTRONICS LLC

One East Commerce Drive
Schaumburg, IL 60173

847-843-7900

For US technical support or other inquiries:

800-556-6766

OMRON CANADA, INC.

885 Milner Avenue
Toronto, Ontario M1B 5V8

416-286-6465

OMRON ON-LINE

Global - <http://www.omron.com>

USA - <http://www.omron.com/oei>

Canada - <http://www.omron.com/oci>